



APPLICATION

The Autofloc 87 is a larger version of the Autofloc 27 for preparing flocculants and any other reagent more intensively and at higher rates, in a single tank. Our AUTOFLOC stations are ready to be hooked up to the water and electricity supplies. They are fully automated and prepare the solution in continuous mode. Some processes are upgradable and the type of polymer used may change.

This is why we have developed stations that can work easily with powder and emulsion polymers. The Autofloc 87 is available in 600- to 6,000-litre versions.

Benefits

- A larger preparation station, but still with a single tank
- Easy to operate and maintain
- Quick preparation times in a fully automated system: little operator input and monitoring.

Powders : the flocculant is stored in a hopper that feeds a variable-rate metering device.

A station consists of a main tank with a low-speed agitator. A flow meter indicates the through-flow rate and a minimum flow switch triggers a low-water alarm and cuts out the powder metering device.

The dilution ratio is obtained by adjusting the water inlet and the flocculant flow. The flocculant solution is ready for use in the process once the tank has been filled. At low level (10% used), the station prepares a new solution until the volume is at the high fill mark. This dilutes the 10% new solution in the 90% mature solution. The upper and lower fill levels represent 10% of the station's fill volume. The control unit houses all the supply systems (agitators, dosing device, solenoid, control, safety device).

OPTIONS

- Specific voltages
- ATEX motor
- Variator
- Final pumps
- Electromagnetic flow meters
- Secondary dilution
- Powder and emulsion system
- Overflow and additional tapplings
- Autolift powder storage system
- High-specification materials (Uranus 52N, Uranus B6, range of coatings, etc)
- Other options are available according to requirements. Contact us for information.

TECHNICAL DATA

Type	Volume (L)	Tank dimensions		
		Leight	Widht	Overall height
8706P	600	1420	1100	1495
8710P	1000	1420	1100	2005
8715P	1500	1420	1100	2005
8725P	2500	1690	1370	2150
8730P	3000	1690	1610	2150
8760P	6000	2500	2180	2300

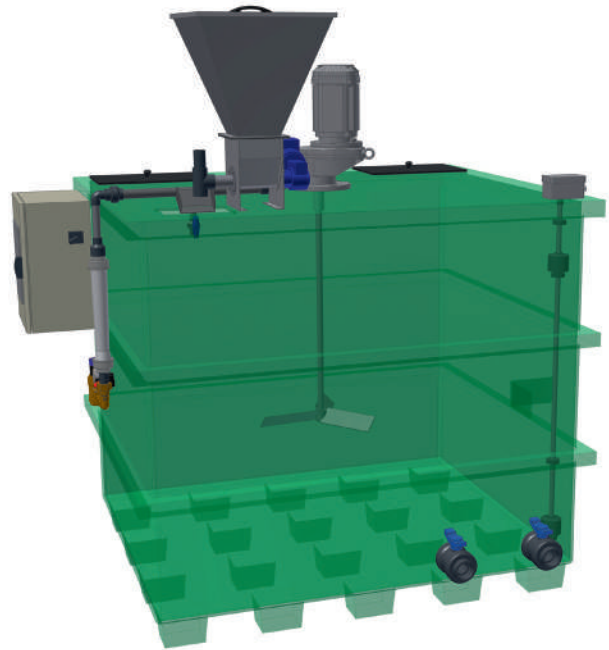
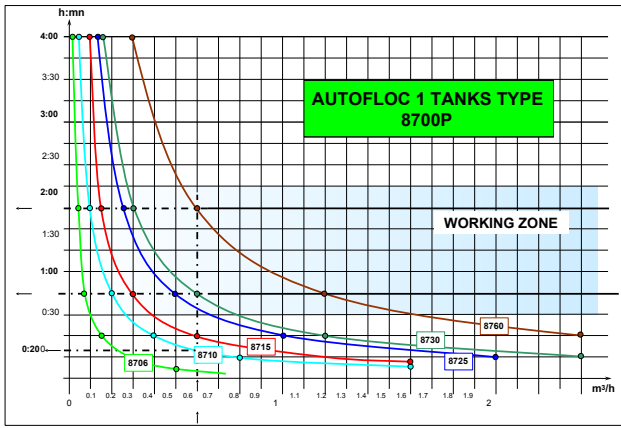

> Drawing for illustration purposes

