

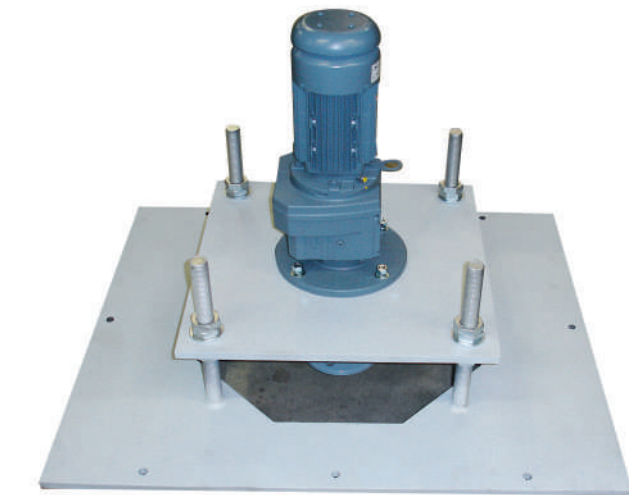

APPLICATION

The optional mounting frame offers a significant benefit when installing and servicing an aerator. With a mounting frame, the aerator can be fitted and removed in one piece and in one operation, without having to be disassembled. On a normal aerator, the relatively large moving mixing section requires the turbine to be disassembled and the gear motor and mounting parts to be individually removed, followed by the moving section from underneath. Our frame is wider than the diameter of the aerator, which allows the entire unit to be lifted by the four corner-mounted lifting lugs.

The mounting frame is an extremely useful option for facilities with difficult access. The result is easy handling and maintenance.



SUMMARY

- The aerator can be removed in one step.
- Easy handling
- Easy to dismantle and maintain
- Solid build

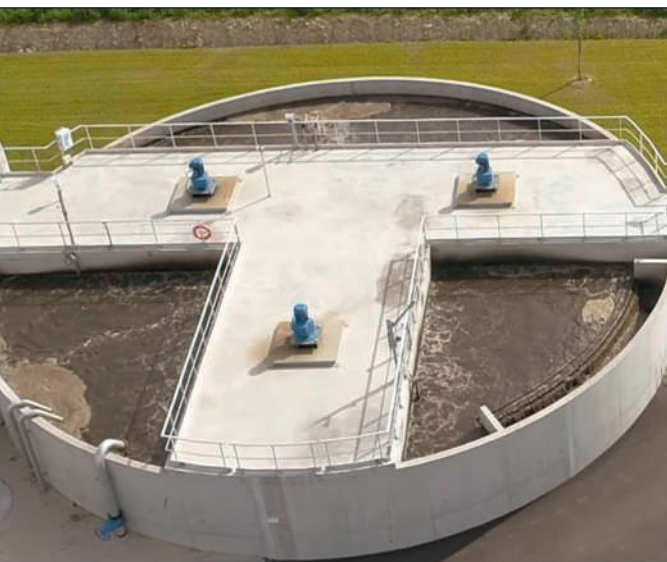

TECHNICAL DATA

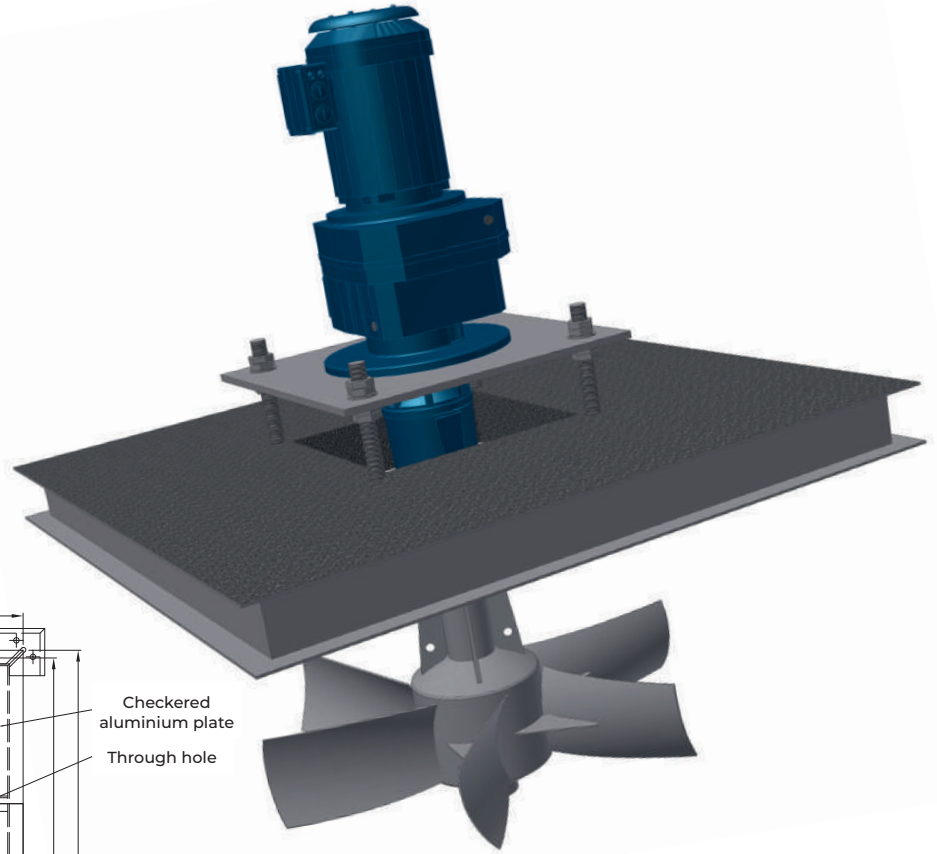

> Drawing for illustration purposes

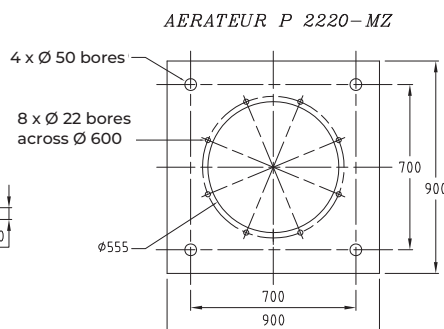
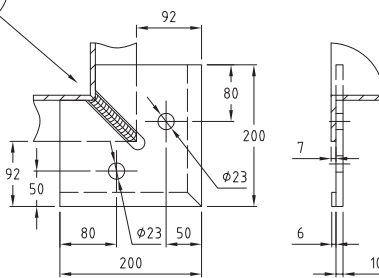
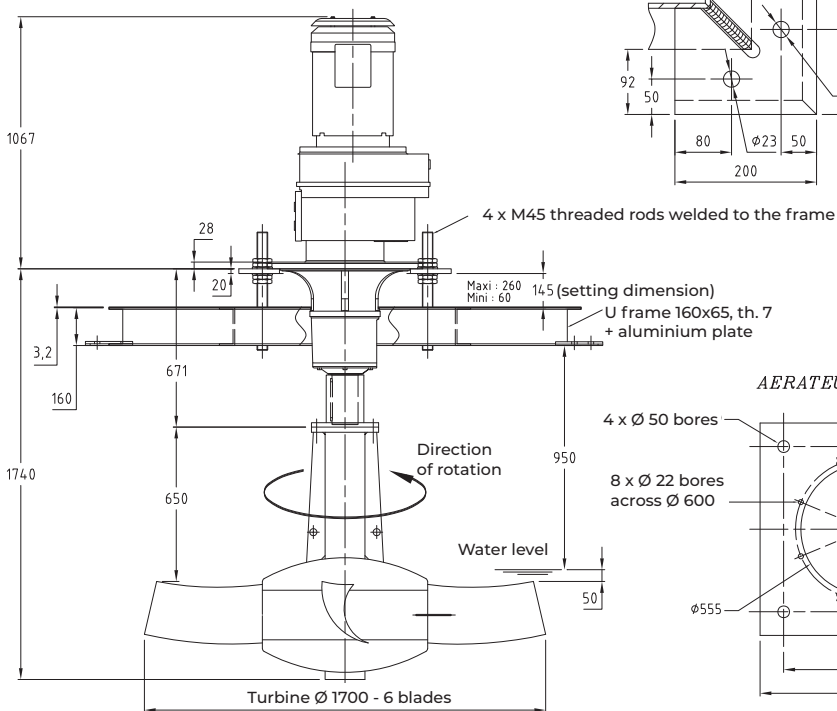
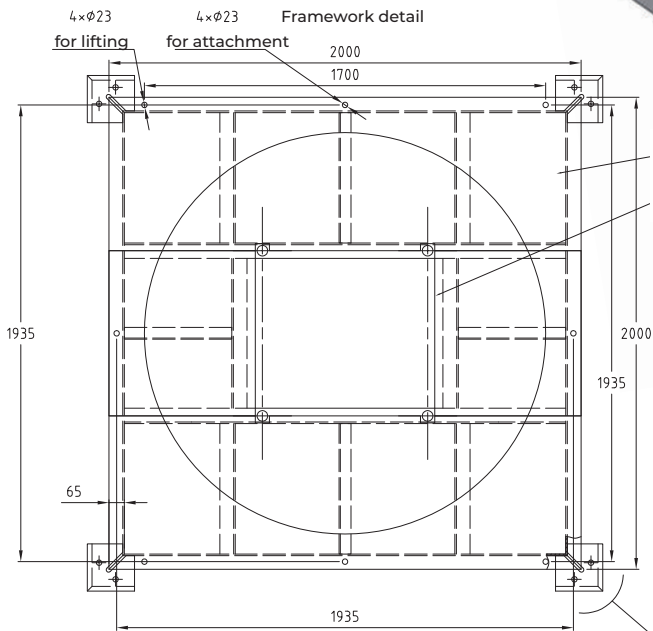

AERATEUR P 2220-MZ