

## APPLICATION

The PPR-Type agitator has a retractable paddle turbine attached to the shaft end and is driven by a socket system mounted directly to the gear shaft. The impeller profile is specially engineered to open out automatically when the shaft begins to turn and fold back when the agitator is switched off. The impeller section can be passed through a bung diameter of just 115 mm.

PPR agitators have a turbine up to 500 mm in diameter, and can also be secured by a mounting plate or a bridge mount with handles for IBCs. We supply with three-phase 50 Hertz tropicalized motors as standard. The standard impeller shaft is made from 316L stainless steel. The PPR agitator is available with multiple options.

## OPTIONS

- Other voltages
- 60 Hz
- Atex motor
- Compressed air motor
- Single-phase motor
- Bevel gear
- Variable frequency drive
- Rain cover
- Power cord and plug
- Control unit with daily timer
- High-specification materials (Uranus 52N, Uranus B6, PVC, range of coatings, etc)
- Other options are available according to requirements. Contact us for information.

## SUMMARY

- Reagent preparations, homogenous mixing, polyelectrolyte preparation
- Perfect for IBCs
- Max. shaft length: 1,050 millimetres
- Standard 230/400 V - Three-phase 50 Hz Tropicalized
- Mounting plate or cross beam with handles
- Multiple options available



# TECHNICAL DATA

OPTIONS
Ø400 FOLDING 2ND IMPELLER
1.1 kW MOTOR - ACC. DENSITY/VISCOSITY
1.5 kW MOTOR - STORAGE > 1 MONTH
460V / 60 Hz MOTOR
SINGLE-PHASE 220 VOLT MOTOR
0.55 kW BEVEL GEAR MOTOR
ATEX II 2G EEX D II CT4 MOTOR
ACS GEAR OIL
IP55 CONTROL UNIT WITH ON/OFF BUTTON
IP55 CONTROL UNIT WITH ON/OFF BUTTON + EMERGENCY SHUTOFF
IP55 CONTROL UNIT WITH ON/OFF BUTTON + DAILY TIMER
IP55 VARIABLE FREQUENCY DRIVE 380 3P POWER
STANDARD 380 3P ELECTRICAL PLUG
CABLE ASSEMBLY WITH 5-METRE CABLE
220 VOLT SINGLE-PHASE IP55 VARIABLE FREQUENCY DRIVE
STANDARD 220 VOLT SINGLE-PHASE ELECTRICAL PLUG
CABLE ASSEMBLY WITH 5-METRE CABLE
1.5 kW COMPRESSED AIR MOTOR
CONTROL UNIT FILTER/LUBRICATOR/ISOLATION VALVE
DIRECT DRIVE HYDRAULIC MOTOR
SLING RINGS
FORK-LIFT ATTACHMENT LUGS
SAFETY SENSOR (STOPS IF NO CONTACT/CONTAINER) ONLY POSSIBLE WITH VARIABLE FREQ.
ATEX SAFETY SENSOR (STOPS IF NO CONTACT/CONTAINER) ONLY POSSIBLE WITH VARIABLE FREQ.
HOPPER ON AGITATOR CROSS BEAM

> Drawing for illustration purposes

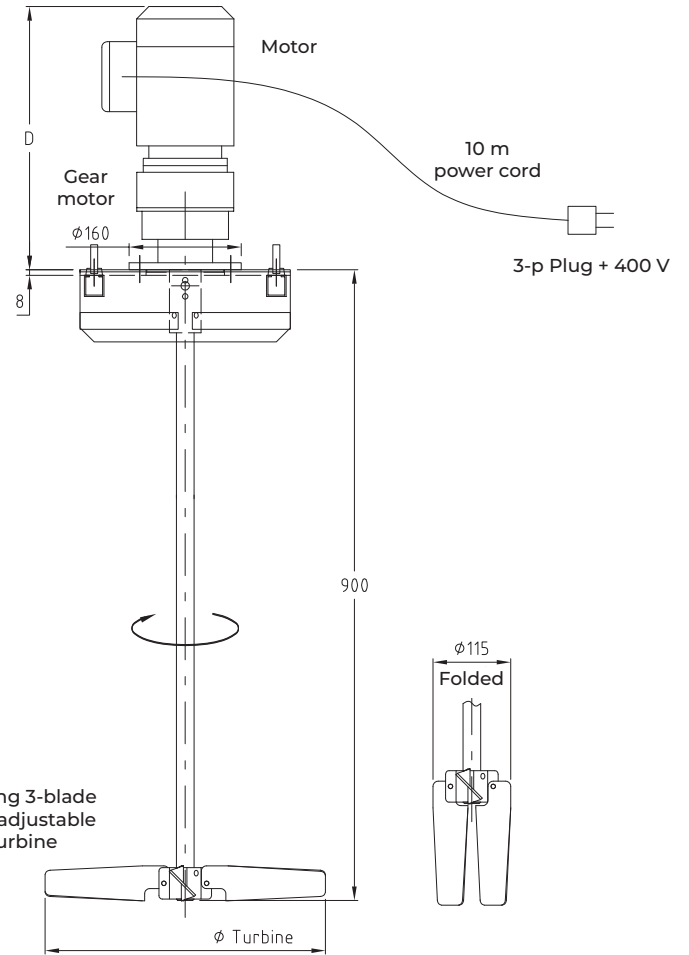

## Container bridge mount

